

## RECOMMENDED MOUNTING INSTRUCTONS

### *For Light Series - 500, 550, 560, 565, 585, EFL5 (rubber based lights)*

**\*\*\*Proper installation of this product is the sole responsibility of the installer\*\*\***

1. Locate a flat surface on vehicle and position light parallel to the ground.
2. In the interior of the vehicle, loosen upholstery at mounting location.
3. Use center-punch if available to start three (3) mounting holes - See below diagram.  
Drill the three holes out using a 1/4" drill bit.
4. Insert wire through center hole (X) and position mounting bolts in holes.
5. Connect **red wire** to power (+) and **black wire** (if provided) to ground (-)
6. If black wire is not provided, light is grounded to a metal surface thru the mounting bolts
7. Follow wiring instructions for a switch if provided ----- TEST LIGHT
8. Install washers and hex nuts and tighten down mounting bolts until rubber base seals light to the surface of the vehicle.
9. Replace upholstery to original position if applicable.

***Check label for proper mounting direction***

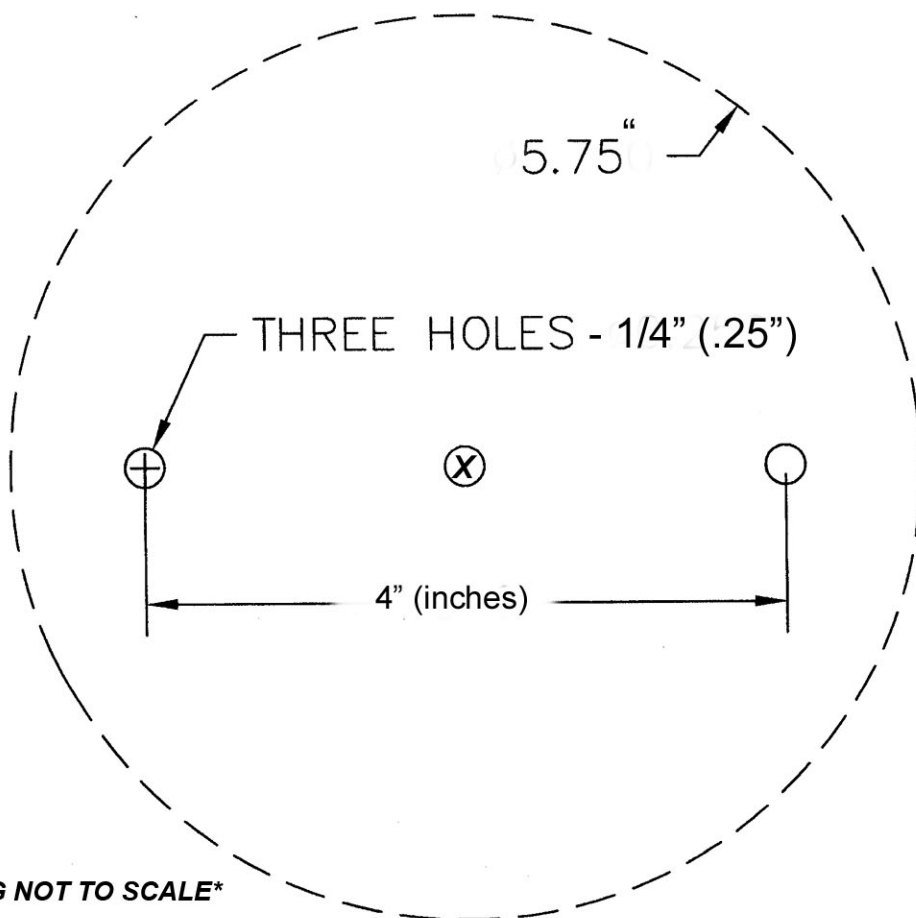

**\*\*\*\*\*CLEAN LENS WITH WATER ONLY\*\*\*\*\***

If you have purchased a magnet mount light be sure to check the owner's manual for lighter/auxiliary socket maximum amparage rating before plugging in any warning light.